

Formal security analysis and certification in industry, at the example of an AADS¹

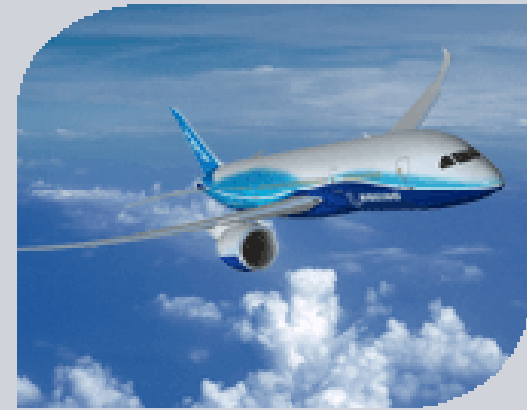

Dr. David von Oheimb
Siemens Corporate Technology, Security

Guest lecture on invitation by Dr. Ricarda Weber at the
CS department of TU Munich, Germany, 01 June 2010

<http://www11.in.tum.de/Veranstaltungen/SecurityEngineeringSS2010/>

¹**Airplane Assets Distribution System**

Overview

- **IT Security at Siemens Corporate Technology**
- Software distribution systems
- Common Criteria certification
- Formal security analysis
- Alice-Bob protocol model
- Validation with AVISPA Tool
- Conclusion on AADS
- Research project AVANTSSAR

Corporate Technology: Role within Siemens

Networking the integrated technology company

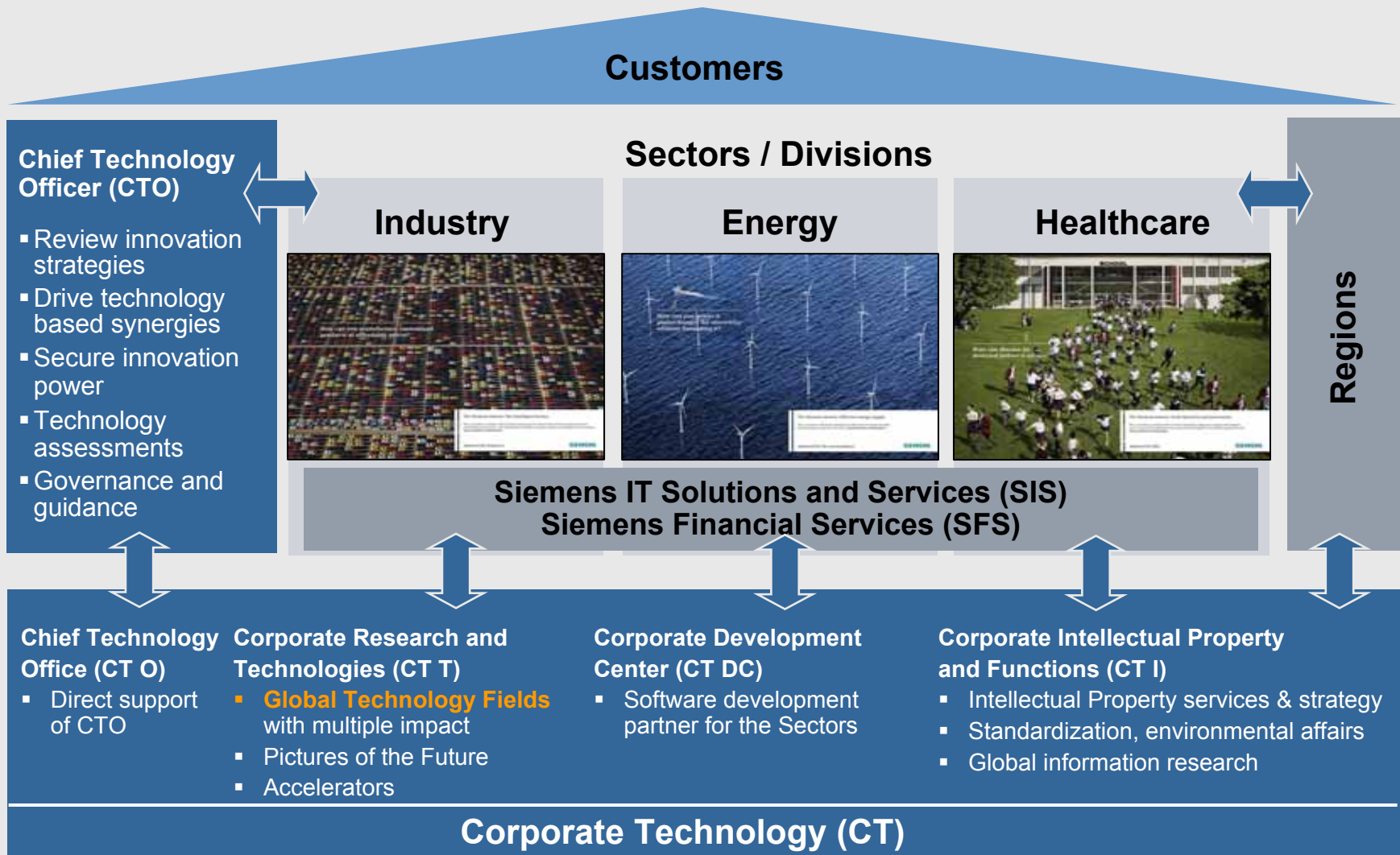

Corporate Technology: around 3,000 R&D employees Present in all leading markets and technology hot spots

SIEMENS



GTF IT-Security – Competences ensure innovation for secure processes and protection of critical infrastructure



Competences Areas

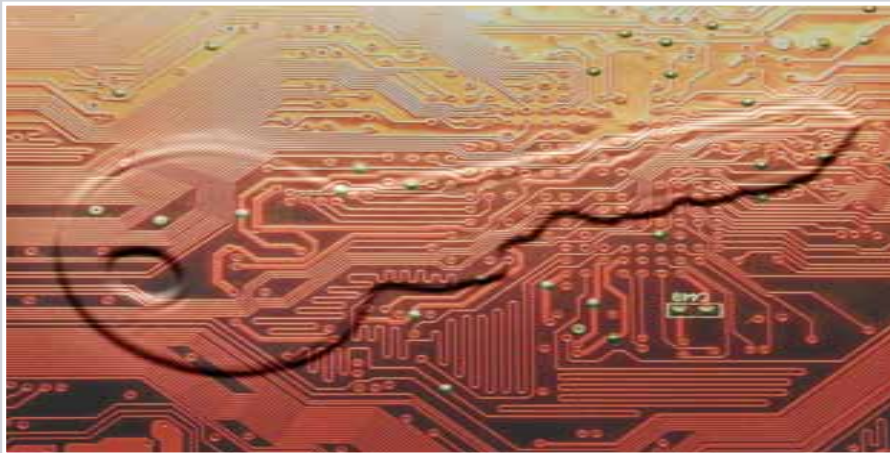

Communication and Network Security

- Secure Communication Protocols and IP-based Architectures
- Sensor & Surveillance Security
- Security for Industrial Networks, Traffic Environments, and Building Technologies

Application Security & Methods

- Secure Service Oriented Architectures
- Enterprise Rights Management
- Trusted Computing
- Control Systems & SCADA Security
- **Certification Support & Formal Methods**

Cryptography

- Security for Embedded Systems
- RFId Security
- Anti-counterfeiting / anti-piracy
- Side Channel Attack Robustness

Fields

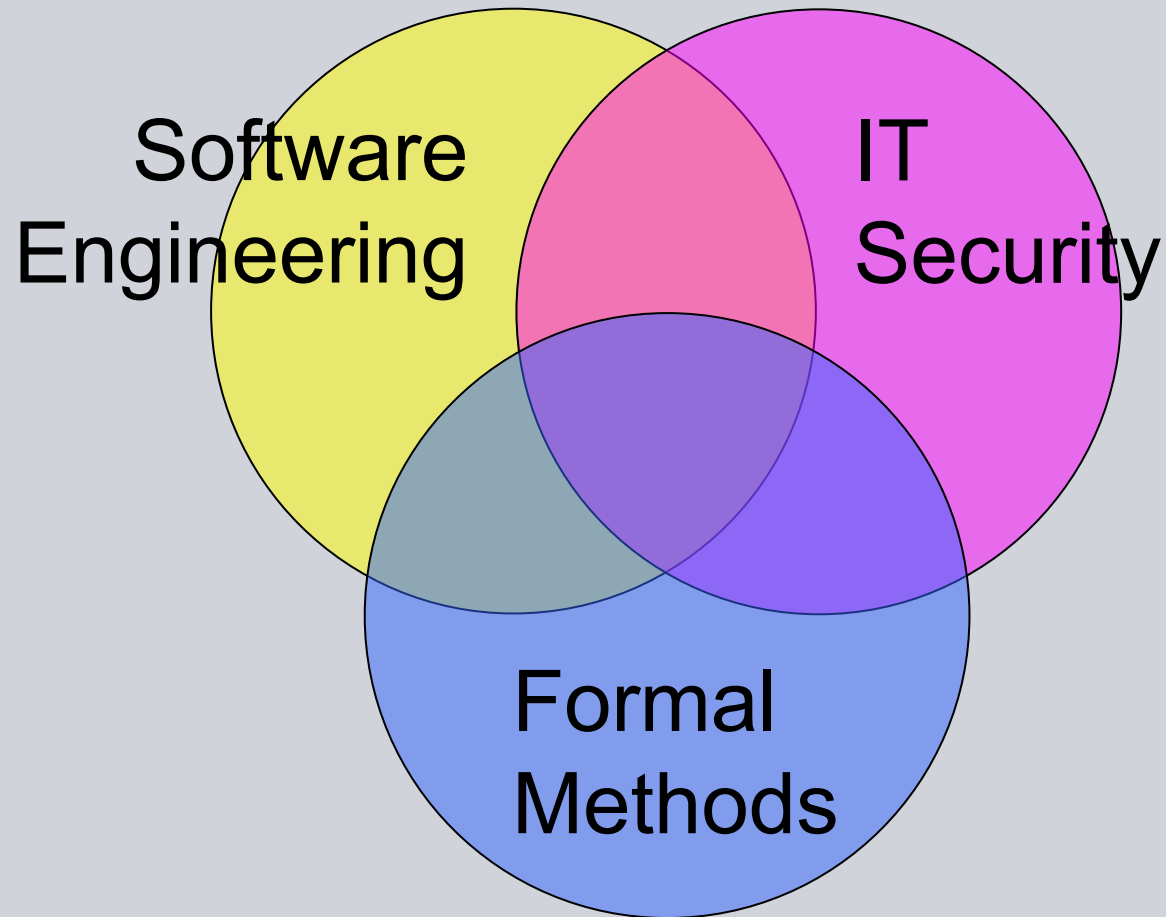

Overview

- IT Security at Siemens Corporate Technology
- **Software distribution systems**
- Common Criteria certification
- Formal security analysis
- Alice-Bob protocol model
- Validation with AVISPA Tool
- Conclusion on AADS
- Research project AVANTSSAR

Airplane Assets Distribution System (AADS)

AADS is a system for storage and distribution of airplane assets, including *Loadable Software Airplane Parts (LSAP)* and airplane health data

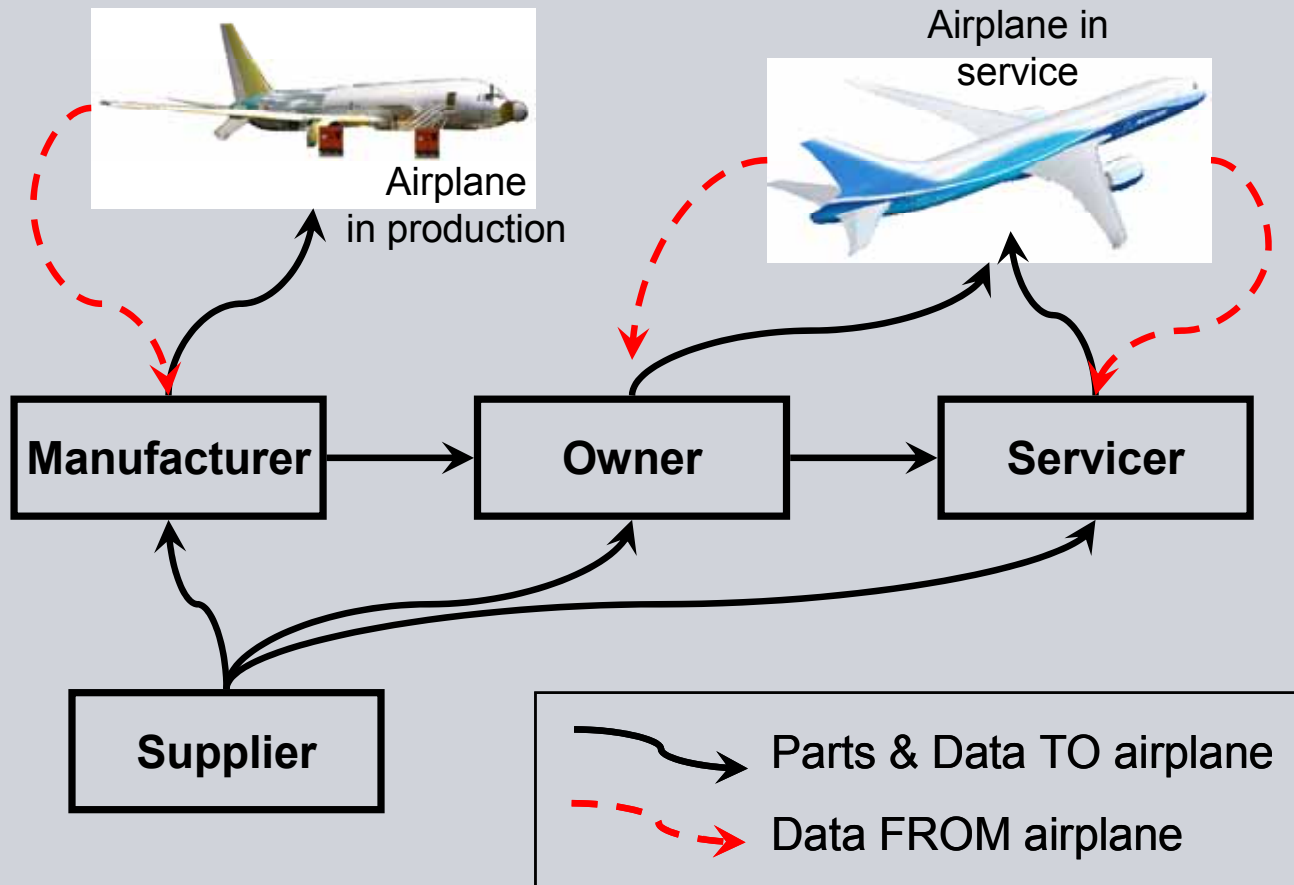

Airplane Assets Distribution System architecture

A complex distributed store-and-forward middleware with OSS components

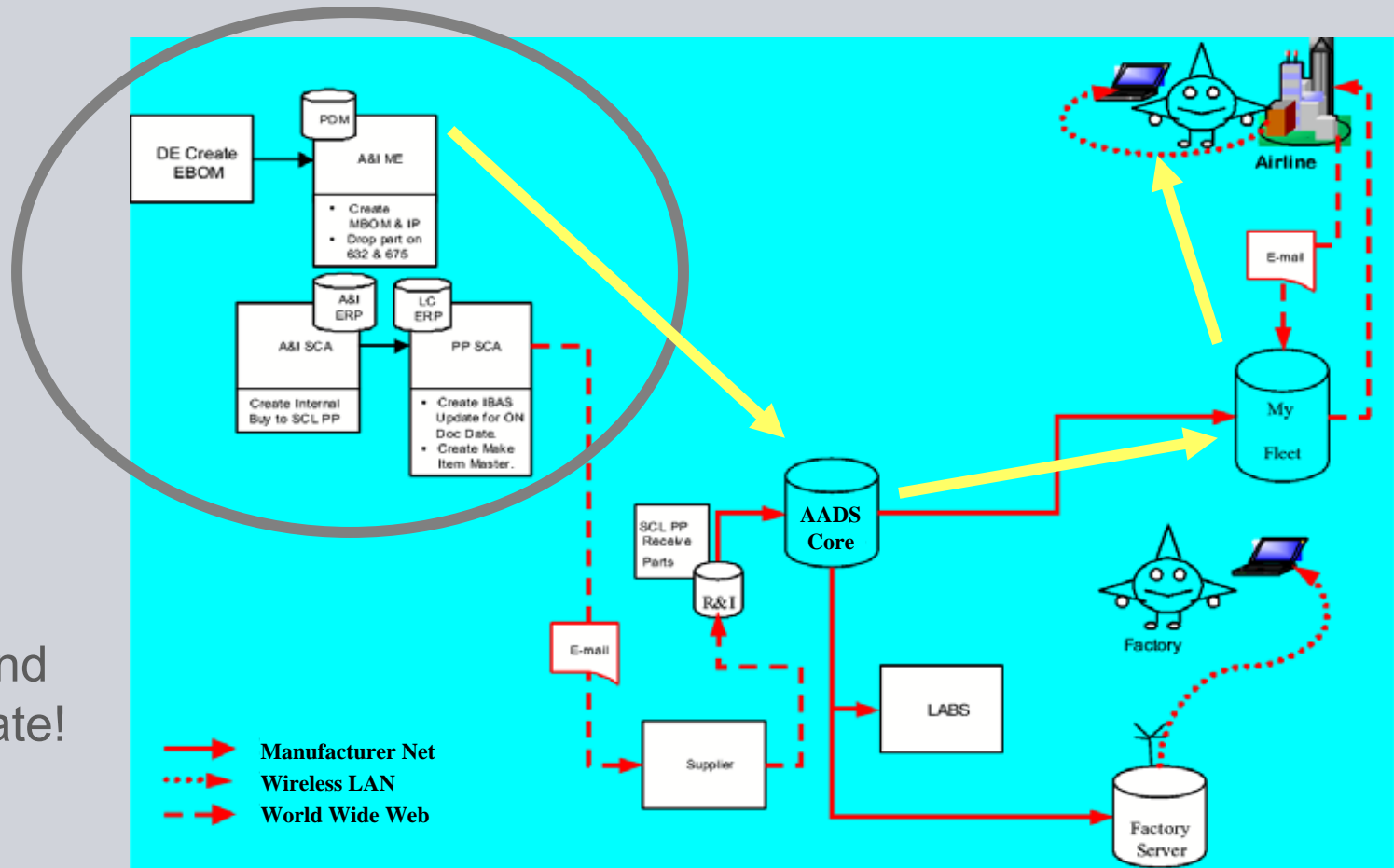
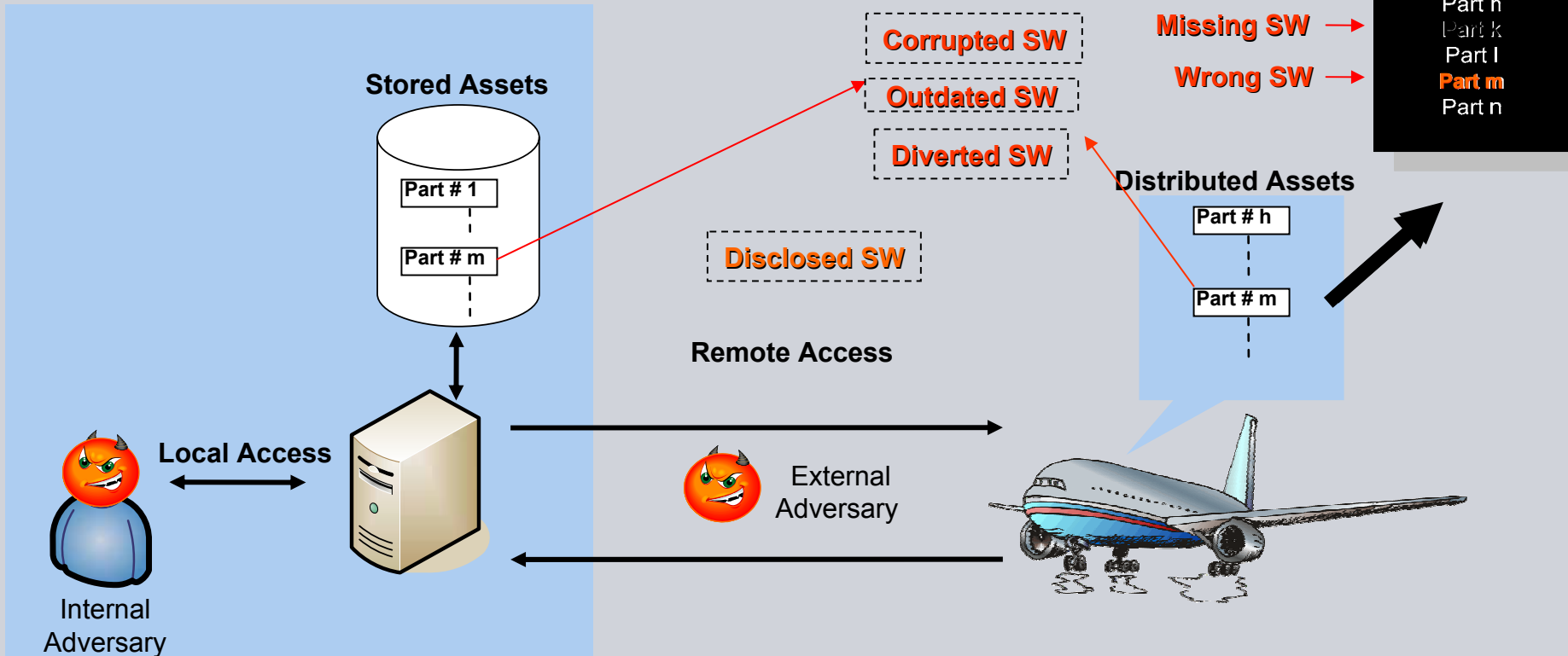

Figure is simplified and not up-to-date!

Security threats at the AADS example

Attacker's objective: lower airplane safety margins by tampering software that will be executed onboard an airplane



Corruption/Injection

Wrong Version

Diversion

Disclosure

Software Distribution System (SDS)

ICT systems with **networked devices** in the field performing **safety-critical** and/or **security-critical** tasks. Field devices require **secure software update**.

→ **Software Distribution System (SDS):**

System providing secure distribution of **software (SW)** from software supplier to target devices in the field

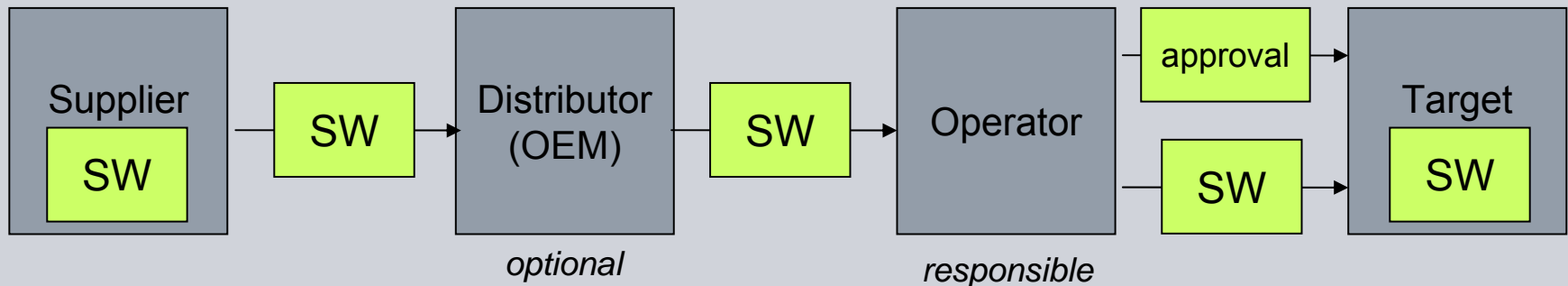

Transition from media-based (CD-ROMs etc.) to **networked SW transport** increases **security risks** due to transport over open, untrusted networks

Software Signer Verifier (SSV)

Each node in SDS runs an SSV instance, used for:

- **Introducing unsigned** software into the SDS, by digitally signing and optionally encrypting it
- **Verifying** the signature on software received from other SSVs, checking integrity, authenticity and authorization of the sender
- **Approving** software by adding an authorized signature
- **Delivering** software out of the SDS after successfully verifying it

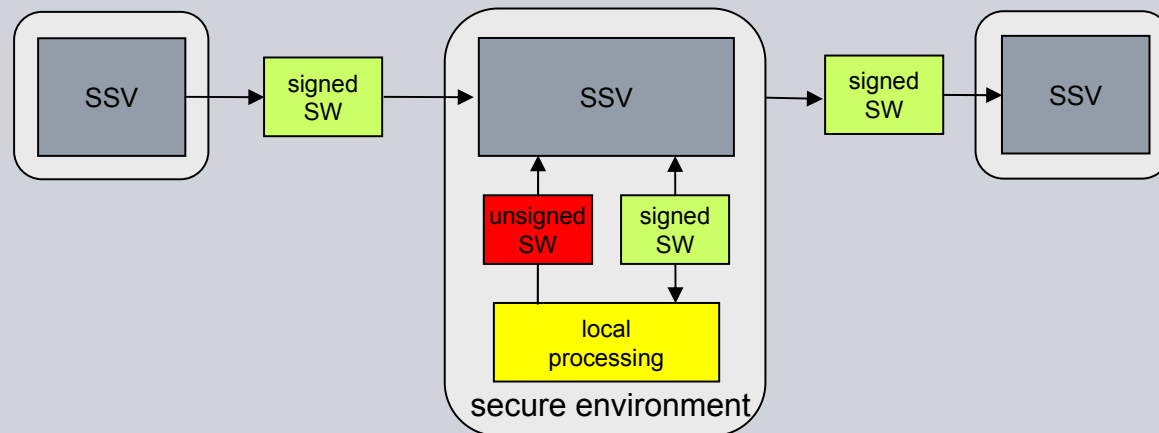

Overview

- **IT Security at Siemens Corporate Technology**
- Software distribution systems
- **Common Criteria certification**
- Formal security analysis
- Alice-Bob protocol model
- Validation with AVISPA Tool
- Conclusion on AADS
- Research project AVANTSSAR

IT Security as a System Engineering Problem

- **IT security** aims at preventing, or at least detecting, unauthorized actions by agents in an IT system.

In the AADS context, security is a prerequisite of safety.

- **Safety** aims at the absence of accidents (→ airworthiness)

Situation: security loopholes in IT systems **actively exploited**

Objective: **thwart attacks** by eliminating vulnerabilities

Difficulty: IT systems are very complex. Security is interwoven with the whole system, so **very hard to assess**.

Remedy: evaluate system following the **Common Criteria** approach

- address security **systematically in all development phases**
- perform document & code reviews and tests
- for maximal assurance, use **formal modeling and analysis**

Common Criteria (CC) for IT security evaluation



product-oriented methodology
for IT security assessment

ISO/IEC standard 15408

Current version: 3.1R3 of Jul 2009

Aim: gain **confidence** in the security of a system

- What are the **objectives** the system should achieve?
- Are the **measures** employed **appropriate** to achieve them?
- Are the measures **implemented and deployed correctly**?

CC General Approach

Approach: assessment of system + documents by neutral experts

- Gaining understanding of the system's security functionality
- Checking evidence that the functionality is correctly implemented
- Checking evidence that the system integrity is maintained

CC Process Scheme

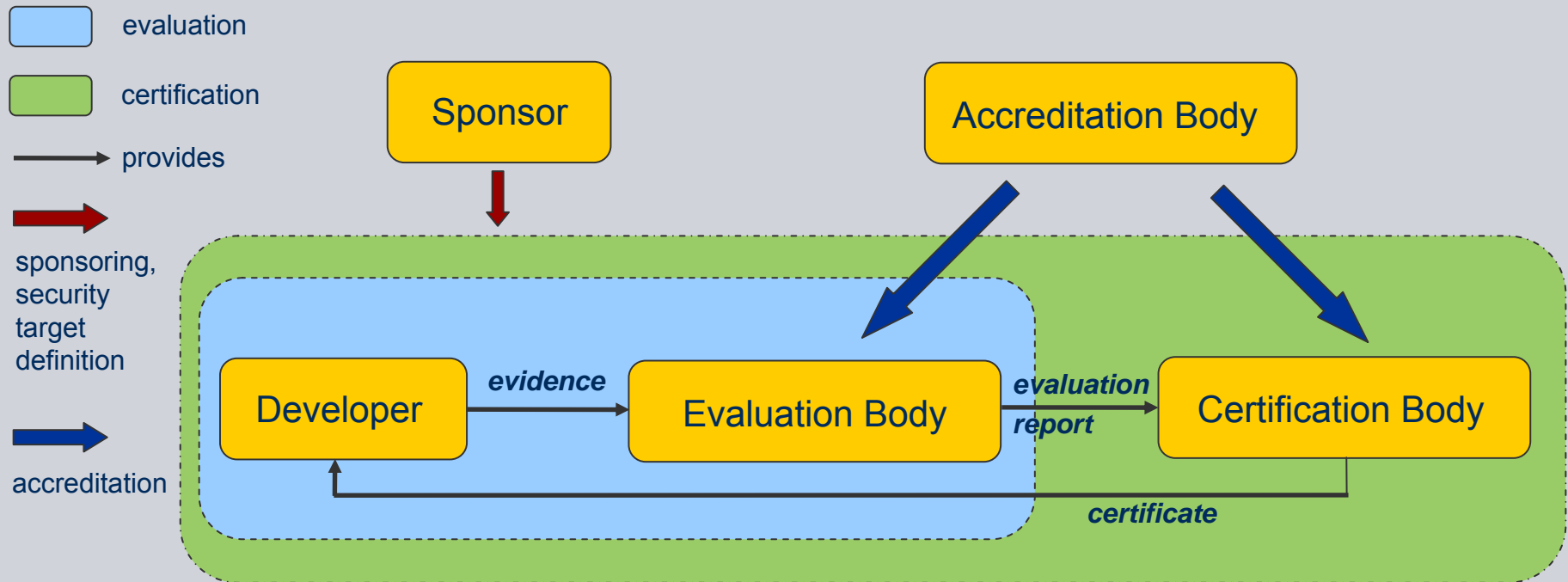

Certification according to the Common Criteria is a rather **complex**, **time consuming** and **expensive** process.

A successful, approved evaluation is awarded a **certificate**.

CC: Security Targets

Security Target (ST): defines extent and depth of the evaluation
for a specific product called *Target of Evaluation (TOE)*

Protection Profile (PP): defines extent and depth of the evaluation
for a whole class of products, i.e. firewalls

STs and PPs may inherit (*'claim'*) other PPs.

ST and PP specifications use **generic** “construction kit”:

- Building blocks for defining *Security Functional Requirements (SFRs)*
- Scalable in depth and rigor: *Security Assurance Requirements (SARs)*

layered as *Evaluation Assurance Levels (EALs)*

AADS Security Specification: CC Protection Profile (1)

1. Introduction
2. System Description - Target of Evaluation (TOE)
3. Security Environment
 - Assets and Related Actions
 - Threats
 - Security Assurance Requirements (EAL)
 - Assumptions
4. Security Objectives
 - ...
 - ...

Security Objectives for the AADS

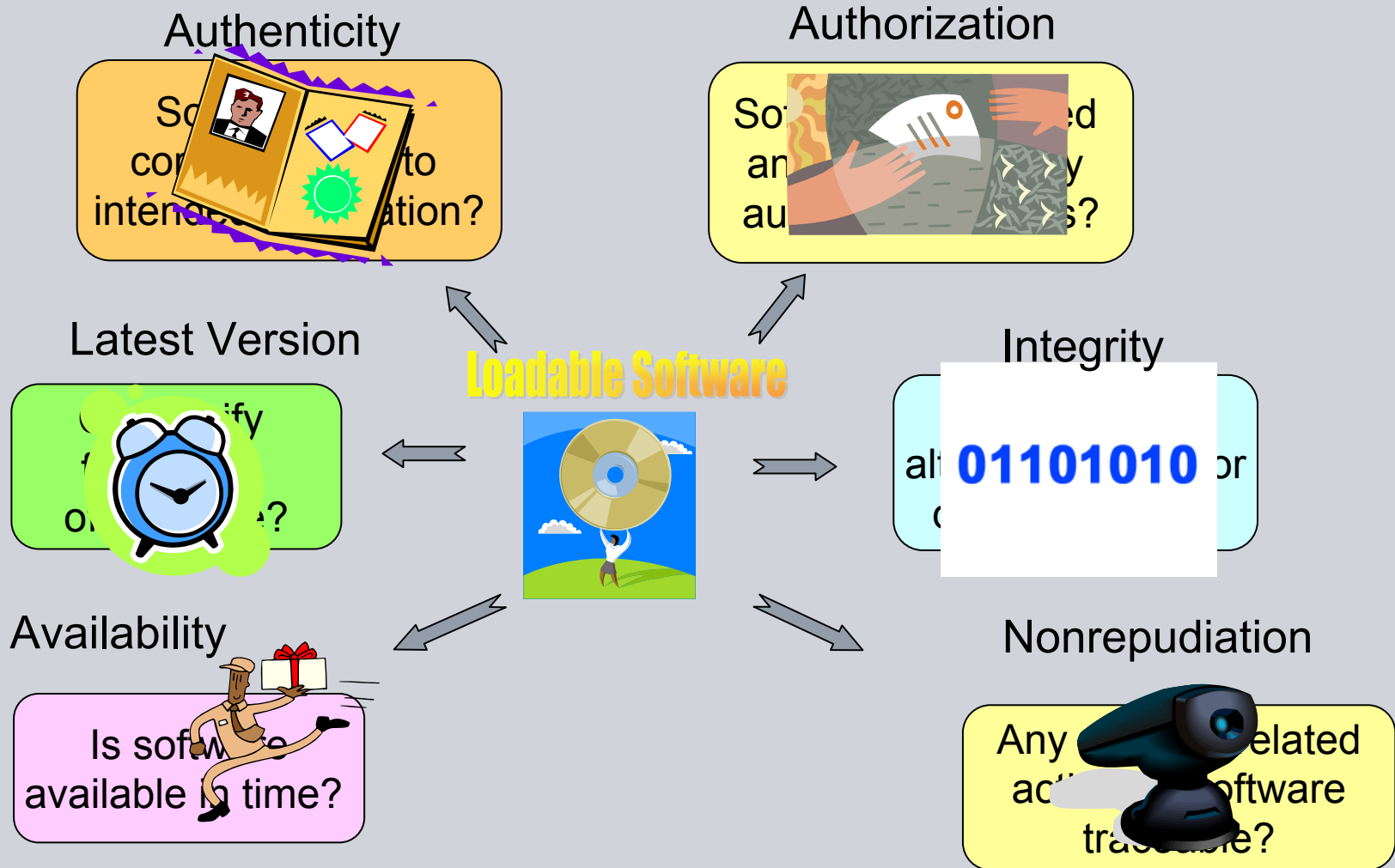

AAADS Security Specification: CC Protection Profile (1a)

1. Introduction
2. System Description - Target of Evaluation (TOE)
3. Security Environment
 - Assets and Related Actions
 - Threats
 - Security Assurance Requirements (EAL)
 - Assumptions
4. Security Objectives
 - ...
 - Rationale (Objectives and Assumptions cover Threats)

Threats Addressed by the AADS Security Objectives

Objectives		Threats	Safety-relevant				Business-relevant			
			Corruption	Misconfiguration	Diversion	Staleness	Unavailability	Late Detection	False Alarm	Repudiation
Safety-relevant	Integrity	√								
	Correct Destination			√						
	Latest Version				√					
	Authentication	√	√						√	
	Authorization	√	√							
	Timeliness				√					
Business-Relevant	Availability					√				
	Early Detection						√			
	Correct Status							√		
	Traceability	√	√						√	
	Nonrepudiation								√	
Environment	Part_Coherence	√	√	√						
	Loading_Interlocks	√	√	√						
	Protective_Channels	√								
	Network_Protection				√	√				
	Host_Protection	√							√	
Assumptions	Adequate_Signing	√								
	Configuration		√							
	Development	√	√	√	√	√	√	√	√	
	Management	√	√						√	

AADS Security Specification: CC Protection Profile (2)

1. Introduction
2. System Description
3. Security Environment
 - Assets and Related Actions
 - Threats
 - Security Assurance Requirements (EAL)
 - Assumptions
4. Security Objectives
 - ...
 - Rationale
5. Security Functional Requirements
 - ...
 - ...

CC: Security Functional Requirements (SFRs) overview

FAU: Security audit

- Security audit automatic response (FAU_ARP)
- Security audit data generation (FAU_GEN)
- Security audit analysis (FAU_SAA)
- Security audit review (FAU_SAR)
- Security audit event selection (FAU_SEL)
- Security audit event storage (FAU_STG)

FCO: Communication

FCS: Cryptographic support

FDP: User data protection

FIA : Identification and authentication

FMT: Security management

FPR: Privacy

FPT: Protection of the TSF

FRU: Resource utilization

FTA: TOE access

FTP: Trusted path/channels

AADS Security Specification: CC Protection Profile (2)

1. Introduction
2. System Description
3. Security Environment
 - Assets and Related Actions
 - Threats
 - Security Assurance Requirements (EAL)
 - Assumptions
4. Security Objectives
 - ...
 - Rationale
5. Security Functional Requirements
 - ...
 - Rationale (omitted here)

AAADS Security Specification: CC Protection Profile (3)

1. Introduction
2. System Description
3. Security Environment
 - Assets and Related Actions
 - Threats
 - Security Assurance Requirements: **Evaluation Assurance Level**
 - Assumptions
4. Security Objectives
 - ...
 - Rationale
5. Security Functional Requirements
 - ...
 - Rationale

CC: EALs

Security Assurance Requirements (SARs)

grouped as

Evaluation Assurance Levels (EALs)

Assurance class	Assurance Family	Assurance Components by Evaluation Assurance Level						
		EAL1	EAL2	EAL3	EAL4	EAL5	EAL6	EAL7
Development	ADV_ARC		1	1	1	1	1	1
	ADV_FSP	1	2	3	4	5	5	6
	ADV_IMP				1	1	2	2
	ADV_INT					2	3	3
	ADV_SPM						1	1
	ADV_TDS		1	2	3	4	5	6
Guidance documents	AGD_OPE	1	1	1	1	1	1	1
	AGD_PRE	1	1	1	1	1	1	1
Life-cycle support	ALC_CMC	1	2	3	4	4	5	5
	ALC_CMS	1	2	3	4	5	5	5
	ALC_DEL		1	1	1	1	1	1
	ALC_DVS			1	1	1	2	2
	ALC_FLR							
	ALC_LCD			1	1	1	1	2
ALC_TAT				1	2	3	3	
Security Target evaluation	ASE_CCL	1	1	1	1	1	1	1
	ASE_ECD	1	1	1	1	1	1	1
	ASE_INT	1	1	1	1	1	1	1
	ASE_OBJ	1	2	2	2	2	2	2
	ASE_REQ	1	2	2	2	2	2	2
	ASE_SPD		1	1	1	1	1	1
	ASE_TSS	1	1	1	1	1	1	1
Tests	ATE_COV		1	2	2	2	3	3
	ATE_DPT			1	2	3	3	4
	ATE_FUN		1	1	1	1	2	2
	ATE_IND	1	2	2	2	2	2	3
Vulnerability assessment	AVA_VAN	1	2	2	3	4	5	5

CC: Evaluation Assurance Level 2

Development	<p>ADV_ARC.1 Security architecture description</p> <p>ADV_FSP.2 Security-enforcing functional specification</p> <p>ADV_TDS.1 Basic design</p>
Guidance documents	<p>AGD_OPE.1 Operational user guidance</p> <p>AGD_PRE.1 Preparative procedures</p>
Life-cycle support	<p>ALC_CMC.2 Use of a CM system</p> <p>ALC_CMS.2 Parts of the TOE CM coverage</p> <p>ALC_DEL.1 Delivery procedures</p>
Security Target Evaluation	<p>ASE_XXX (<i>6 families of components</i>)</p>
Tests	<p>ATE_COV.1 Evidence of coverage</p> <p>ATE_FUN.1 Functional testing</p> <p>ATE_IND.2 Independent testing - sample</p>
Vulnerability analysis	<p>AVA_VAN.2 Vulnerability analysis</p>

CC: Evaluation Assurance Level 4

Development	ADV_FSP.4 Complete functional specification ADV_IMP.1 Implementation representation of the TSF ADV_TDS.3 Basic modular design
Guidance documents	
Life-cycle support	ALC_CMC.4 Production support, acceptance procedures and automation ALC_CMS.4 Problem tracking CM coverage ALC_DVS.1 Identification of security measures ALC_LCD.1 Developer defined life-cycle model ALC_TAT.1 Well-defined development tools
Security Target Evaluation	
Tests	ATE_COV.2 Analysis of coverage ATE_DPT.2 Testing: security enforcing modules
Vulnerability analysis	AVA_VAN.3 Focused vulnerability analysis

CC: Evaluation Assurance Level 6

Development	ADV_FSP.5 Complete semi-formal functional spec. with additional error information ADV_IMP.2 Implementation of the TSF ADV_INT.3 Minimally complex internals ADV_SPM.1 Formal TOE security policy model ADV_TDS.5 Complete semiformal modular design
Guidance documents	
Life-cycle support	ALC_CMC.5 Advanced support ALC_CMS.5 Development tools CM coverage ALC_DVS.2 Sufficiency of security measures ALC_TAT.3 Compliance with implementation standards – all parts
Security Target Evaluation	
Tests	ATE_COV.3 Rigorous analysis of coverage ATE_DPT.3 Testing: modular design ATE_FUN.2 Ordered functional testing
Vulnerability analysis	AVA_VAN.5 Advanced methodical vulnerability analysis

CC: Factors determining the evaluation effort

- Boundary of TOE vs. TOE environment
- Definition of Threats and Security Objectives for the TOE
- Definition of Security Functional Requirements (SFRs)
- Selection of Evaluation Assurance Level (EAL)

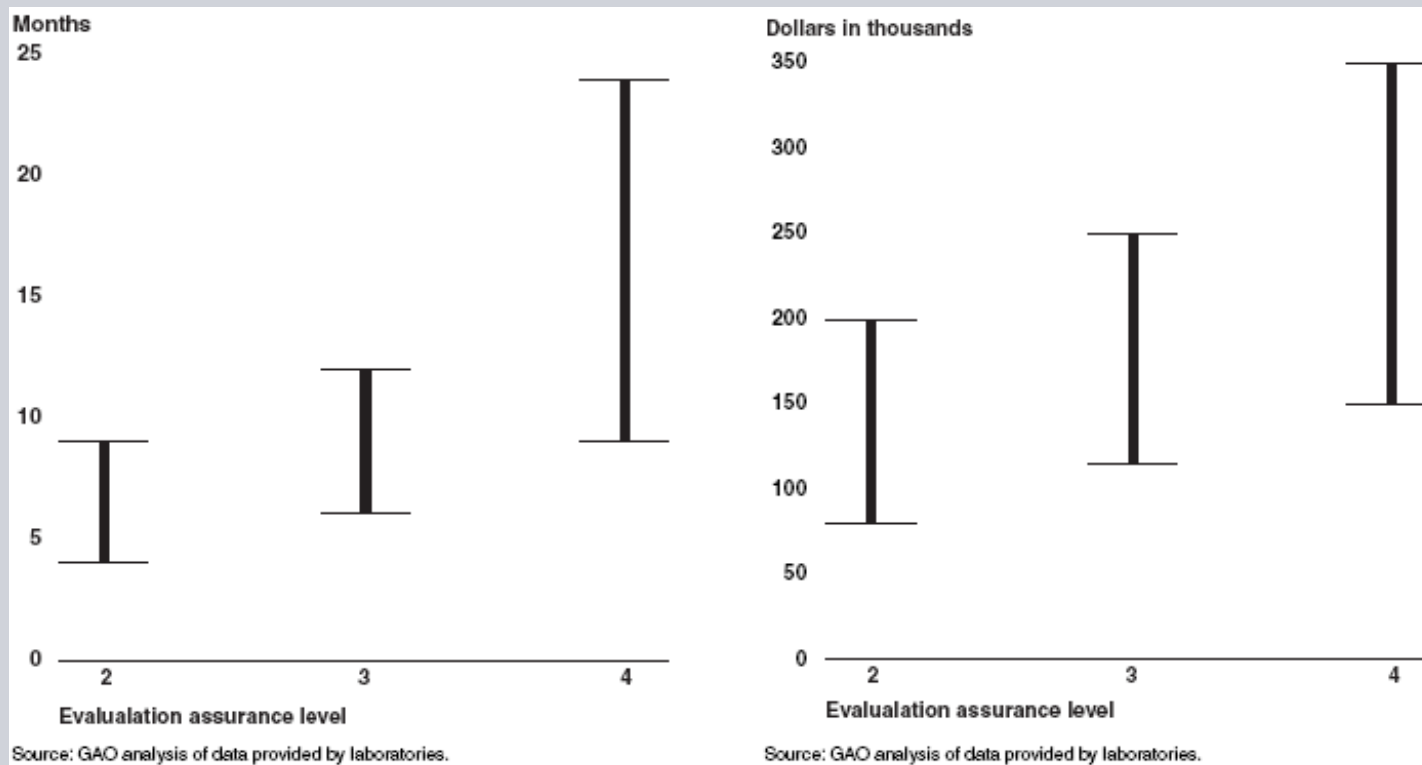

Selection of Evaluation Assurance Level (EAL) for AADS

	Flight safety	Airline business
Threat Level assume sophisticated adversary with moderate resources who is willing to take XXX risk	T5: XXX = significant e.g. intl. terrorists	T4: XXX = little e.g. organized crime, sophisticated hackers, intl. corporations
Information Value violation of the protection policy would cause YYY damage to the security, safety, financial posture, or infrastructure of the organization	V5: YYY= exceptionally grave Risk: loss of lives	V4: YYY = serious Risk: airplanes out of service, or damage airline reputation
Evaluation Assurance Level for the given Treat Level and Information Value	EAL 6: semiformally verified design and tested	EAL 4: methodically designed, tested, and reviewed

Evaluating the whole AADS at EAL 6 would be extremely costly.

Currently available Public Key Infrastructure (PKI) certified only at EAL 4.

Two-level approach: evaluate only LSAP integrity & authenticity at EAL6.

Hybrid security assessment

- Highest CC evaluation assurance levels (EAL 6-7) require formal analysis
- SDS usually are complex distributed systems with many components

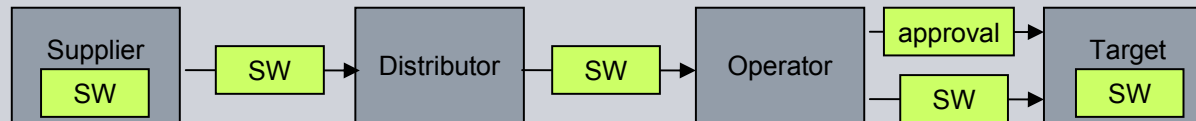

General problems:

- Highly critical system, but (complete) formal analysis too costly
- CC offer only limited support (“CAP”) for modular system evaluation

Pragmatic approach:

- Define **confined security kernel** with generic component: SSV
- **Software Signer Verifier (SSV)** handles digital signatures at each node
- Evaluate **SSV** according to Common Criteria EAL4 (non-formal)
- Analyze the interaction of SSVs in a formal way (→ crypto protocol)

Overview

- IT Security at Siemens Corporate Technology
- Software distribution systems
- Common Criteria certification
- **Formal security analysis**
- Alice-Bob protocol model
- Validation with AVISPA Tool
- Conclusion on AADS
- Research project AVANTSSAR

Formal Security Analysis: Approach and Benefits

Mission: security analysis with **maximal precision**

Approach: **formal modeling and verification**

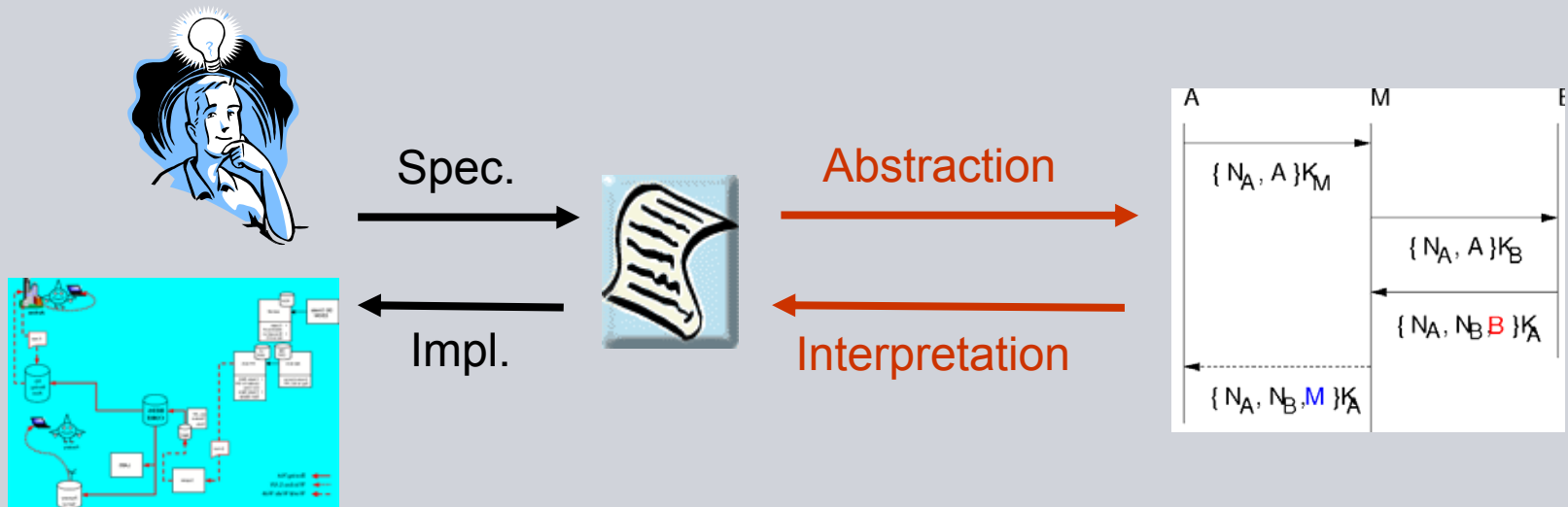

Improving the **quality**
of the system **specification**

Checking for the existence
of **security loopholes**

High-Level Protocol Spec. Language
Model checkers (**AVISPA tools**)

Interacting State Machines
Interactive theorem prover (**Isabelle**)

Formal Security Models

- ▶ A **security policy** defines **what is allowed** (actions, data flow, ...) typically by a relationship between **subjects** and **objects**.
- ▶ A **security model** is a (+/- formal) **description** of a policy and enforcing mechanisms, usually in terms of system **states** or state sequences (**traces**).
- ▶ **Security verification** proves that **mechanisms enforce policy**.
- ▶ Models focus on **specific characteristics** of the reality (policies).
- ▶ Types of formal security models
 - ▶ Automata models
 - ▶ Access Control models
 - ▶ Information Flow models
 - ▶ Cryptoprotocol models

Interacting State Machines (ISMs)

Automata with (nondeterministic) **state transitions** + **buffered I/O, simultaneously** on multiple connections.

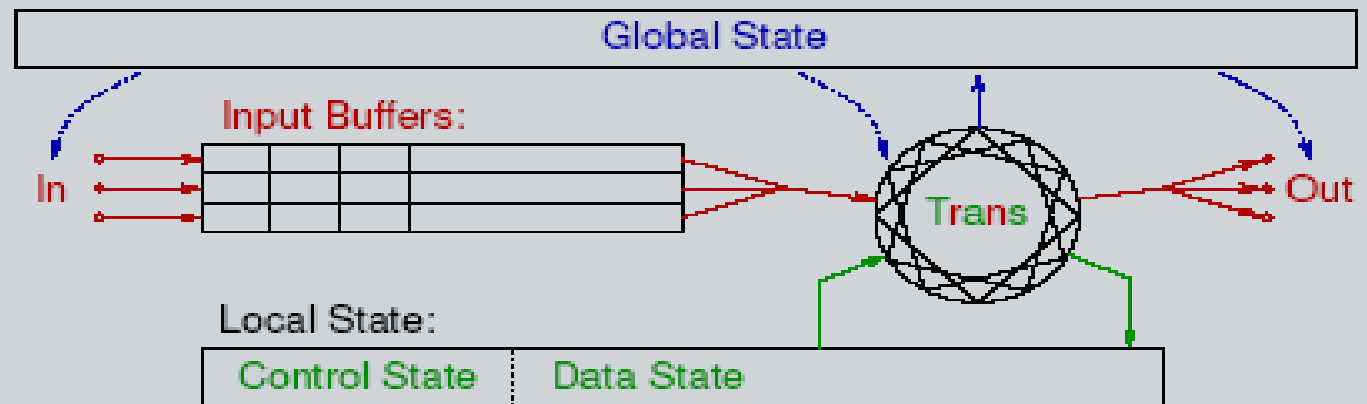

Transitions definable in executable and/or axiomatic style.
 An ISM system may have changing **global state**.
 Applicable to a large **variety of reactive systems**.
By now, not much verification support (theory, tools).

Formal model of Infineon SLE 66 Smart Card Processor

System Structure Diagram:

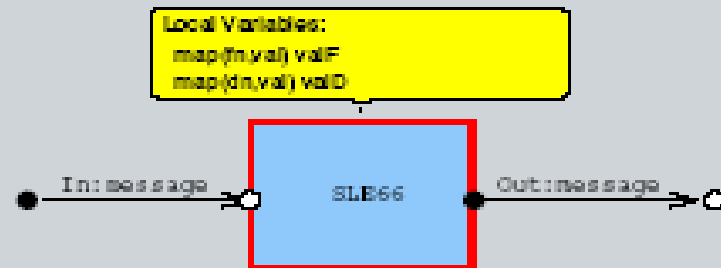

State Transition Diagram (abstracted):

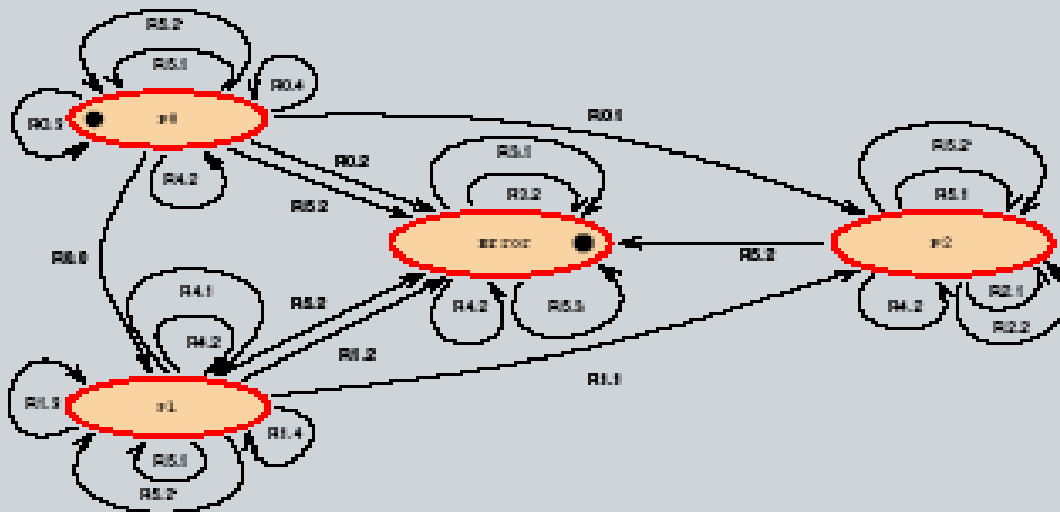

First higher-level (EAL5) certification for a smart card processor!

Formal RBAC model of Complex Information System

Is the security design (with emergency access etc.) sound?

Privileges:

$roles \subseteq user \times role$

$subroles \subseteq role \times role$

$privs \subseteq role \times privilege$

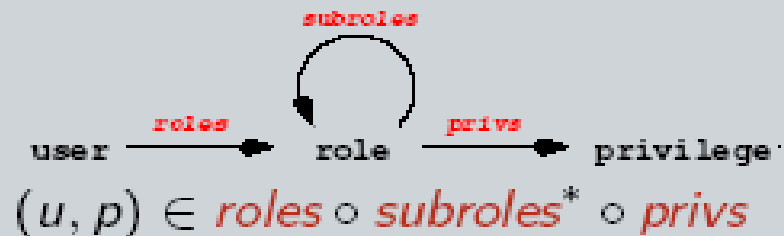

Permissions:

$groups \subseteq user \times group$

$subgroups \subseteq group \times group$

$gperms \subseteq group \times permission$

$uperms \subseteq user \times permission$

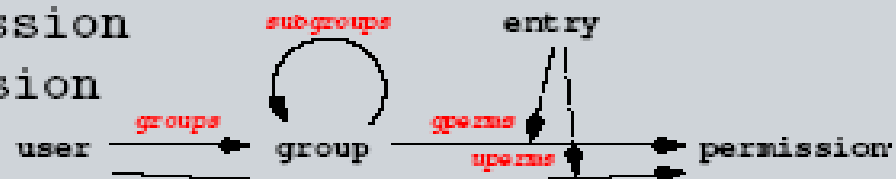

“nagging questions” \rightsquigarrow **clarifications** improving specification quality.

Open issue: relation between model and implementation (\rightsquigarrow testing).

Information Flow Models

- ▶ Identify knowledge/information domains
 - ▶ Specify **allowed flow** between domains
 - ▶ Check the **observations** that can be made about state and/or actions
 - ▶ Consider also **indirect and partial flow**
-
- ▶ Classical model:
Noninterference (Goguen & Meseguer)
 - ▶ Many variants:
Non-deducability, Restrictiveness, Non-leakage, ...

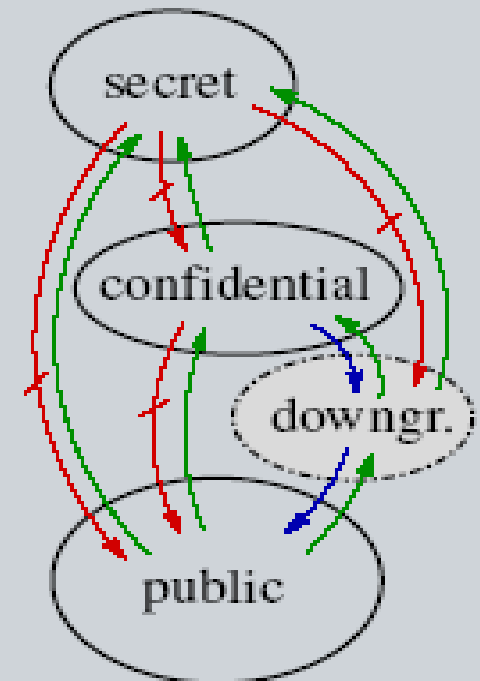

Very strong, but rarely used in practice

Available: connection with ISMs

Language-based Information Flow Security

Policy: no assignments of **high**-values to low-variables, enforced by type system

Semantically: take (x, y) as elements of the **state space** with high-level data (**on left**) and low-level data (on right).

Step function $S(x, y) = (S_H(x, y), S_L(x, y))$

does not leak information from high to low

if $S_L(x_1, y) = S_L(x_2, y)$ (functional **independence**).

Observational equivalence $(x, y) \stackrel{L}{\sim} (x', y') \iff y = y'$

allows re-formulation:

$$s \stackrel{L}{\sim} t \longrightarrow S(s) \stackrel{L}{\sim} S(t) \quad (\text{preservation of } \stackrel{L}{\sim})$$

Generalization to action sequences α and arbitrary policies \rightsquigarrow

Cryptoprotocol models

- ▶ Describe **message exchange** between processes or principals



- ▶ Take **cryptographic operations** as **perfect** primitives
- ▶ Describe system with specialized modeling languages
- ▶ State **secrecy, authentication, ...** goals
- ▶ Verify (mostly) **automatically** using model-checkers

EU project **AVISPA**, ...

Example: H.530 Mobile Roaming Authentication

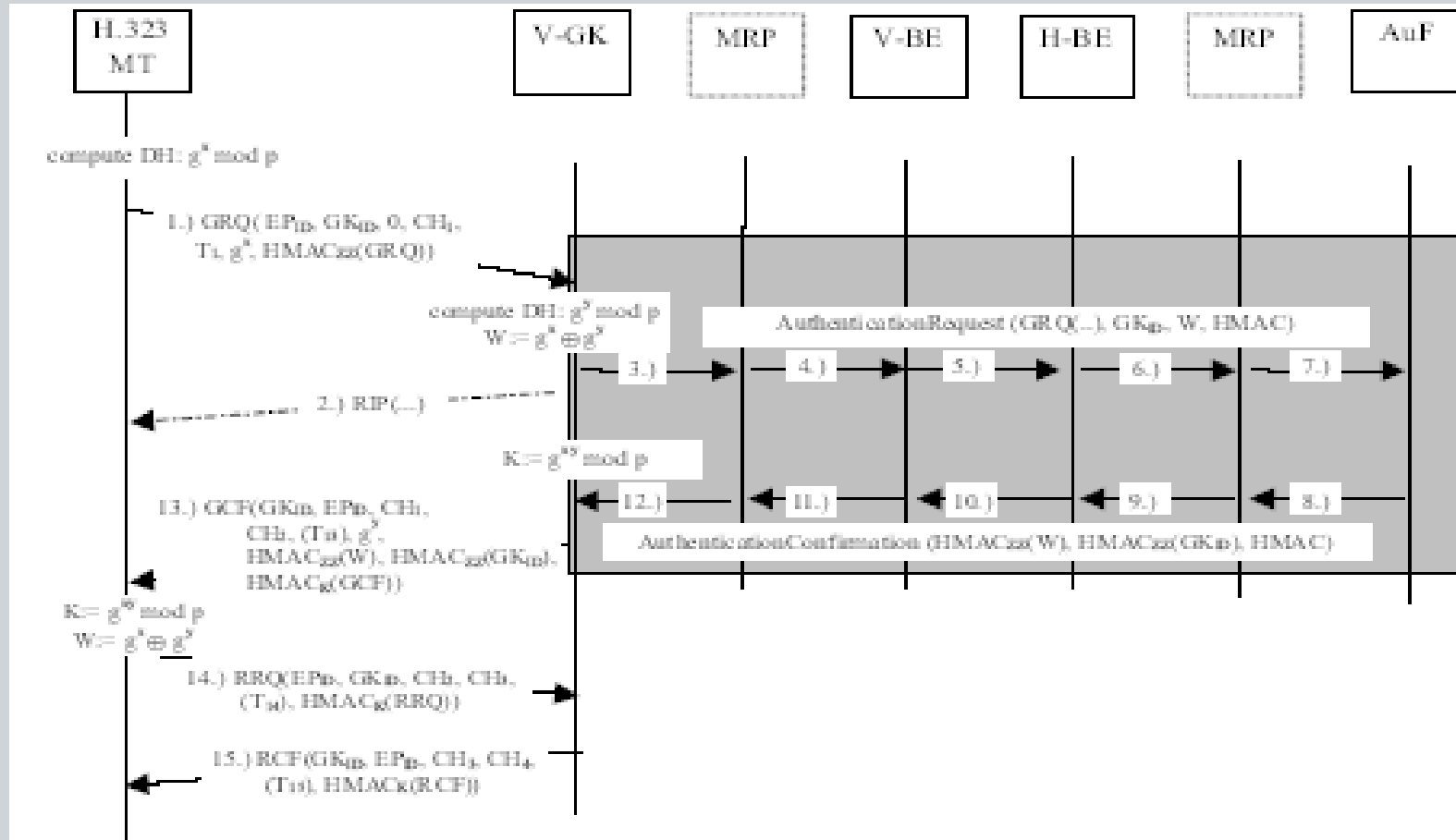

Two vulnerabilities found and corrected. Solution standardized.

Shaping a Formal Model

Formality Level: should be adequate:

- ▶ the more formal, the more **precise**,
- ▶ but requires deeper mastering of formal methods

Choice of Formalism: dependent on ...

- ▶ application domain, modeler's experience, tool availability, ...
- ▶ formalism should be **simple, expressive, flexible, mature**

Abstraction Level: should be ...

- ▶ high enough to achieve **clarity** and limit the **effort**
- ▶ low enough not to lose **important detail**

refinement allows for both high-level and detailed description

Formal Security Analysis: Information Required

- **Overview:** system architecture (components and interfaces), e.g. databases, authentication services, connections,...
- **Security-related concepts:** actors, assets, states, messages, ...
- **Threats:** which attacks have to be expected.
- **Assumptions:** what does the environment fulfill.
- **Security objectives:** what the system should achieve.
Described **in detail** such that concrete verification goals can be set up
e.g. integrity: which contents shall be modifiable by whom, at which times, by which operations (and no changes otherwise!)
- **Security mechanisms:** relation to objectives and how they are achieved.
e.g. who signs where which contents, and where is the signature checked
Described **precisely** but **at high level** (no implementation details required),
e.g. abstract message contents/format but not concrete syntax

Development Phases and the Benefits of Formal Analysis

Requirements analysis:

understanding the security issues

- **abstraction**: concentration on essentials, to keep overview
- **genericity**: standardized patterns simplify the analysis

Design, documentation:

quality of specifications

- **enforces preciseness** and **completeness**

Implementation:

effectiveness of security functionality

- formal model as precise reference for **testing and verification**

Overview

- IT Security at Siemens Corporate Technology
- Software distribution systems
- Common Criteria certification
- Formal security analysis
- **Alice-Bob protocol model**
- Validation with AVISPA Tool
- Conclusion on AADS
- Research project AVANTSSAR

Formal modeling: Alice-Bob notation

```

SUP - {Asset . {h(Asset) . DIS} _inv(KSUP) . CertSUP} _KDIS -> DIS
DIS - {Asset . {h(Asset) . DIS} _inv(KSUP) . CertSUP
      . {h(Asset) . OP } _inv(KDIS) . CertDIS} _KOP -> OP
OP - {Asset . {h(Asset) . DIS} _inv(KSUP) . CertSUP
     . {h(Asset) . OP } _inv(KDIS) . CertDIS
     . {h(Asset) . TD } _inv(KOP ) . CertOP } _KTD -> TD

```

$A - M -> B$ message M sent from A to B

$Asset$ a software item including its identity

$h(M)$ the hash value (i.e. crypto checksum) of content M

$M.N$ the concatenated contents of M and N

$\{M\}_{inv(K)}$ content M digitally signed with private key K

$\{M\}_K$ content M encrypted with public key K

Formal modeling: SDS protocol structure

```

SUP - {Asset . {h(Asset) . DIS }_inv(KSUP) . CertSUP }_KDIS -> DIS
DIS - {Asset . {h(Asset) . DIS }_inv(KSUP) . CertSUP
      . {h(Asset) . OP }_inv(KDIS) . CertDIS }_KOP -> OP
OP - {Asset . {h(Asset) . DIS }_inv(KSUP) . CertSUP
     . {h(Asset) . OP }_inv(KDIS) . CertDIS
     . {h(Asset) . TD }_inv(KOP ) . CertOP }_KTD -> TD

```

SUP : software supplier	with private key <code>inv(KSUP)</code>
DIS : software distributor	with private key <code>inv(KDIS)</code>
OP : target operator	with private key <code>inv(KOP)</code>
TD : target device	with private key <code>inv(KTD)</code>

Signatures comprise hash value of asset and **identity of intended receiver**

Signatures are applied **in parallel** (rather than nested or linearly)

Formal modeling: SDS approvals and certificates

```

SUP - {Asset. {h(Asset).DIS}_inv(KSUP). CertSUP}_KDIS -> DIS
DIS - {Asset. {h(Asset).DIS}_inv(KSUP). CertSUP
      . {h(Asset).OP}_inv(KDIS). CertDIS}_KOP -> OP
OP   - {Asset. {h(Asset).DIS}_inv(KSUP). CertSUP
      . {h(Asset).OP}_inv(KDIS). CertDIS
      . {h(Asset). TD}_inv(KOP)}. CertOP}_KTD -> TD

```

- Approval information partially modelled: **operator** determines **target**
- **Certificate** of a node relates its identity with its public key, e.g. certificate of supplier SUP: $\text{CertSUP} = \{\text{SUP.KSUP}\}_{\text{inv}(\text{KCA})}$
- Certificate authority (CA) with private key $\text{inv}(\text{KCA})$
- Certificates are **self-signed or signed by CA**
- Locally stored sets of public keys of trusted SSVs and CAs

Overview

- IT Security at Siemens Corporate Technology
- Software distribution systems
- Common Criteria certification
- Formal security analysis
- Alice-Bob protocol model
- **Validation with AVISPA Tool**
- Conclusion on AADS
- Research project AVANTSSAR

Verification goals

Show asset **authenticity & integrity (end-to-end)** and **confidentiality**:

- assets accepted by target have indeed been sent by the supplier
- assets accepted by target have not been modified during transport
- assets remain secret among the SSV instances

Asset authenticity & integrity **also hop-by-hop**

Correct destination covered:

- Name of the intended receiver in signed part, checked by target.
Signature of the operator acts as installation approval statement

Correct version not modelled:

- Version info is integrity protected, but
checks delegated to SSV local environment

The AVISPA model

- Alice-Bob notation not detailed and precise enough
- Use the specification language of the AVISPA Tool: **HLPSL**
- Software Signer Verifier (SSV) as **parameterized role** (node class)
- SDS as communication **protocol** linking different SSV instances
- **Multiple** protocol **sessions** describing individual SW transports

Detailed model omitted here

Results of the AVISPA tools

Details on use of the tools omitted here

Verification successful for small number of protocol sessions

- Modelcheckers at their complexity limits, due to
 - parallel signatures, only the latest one being checked
 - multiple instances of central nodes (e.g. manufacturer)
 - ...?

Overview

- IT Security at Siemens Corporate Technology
- Software distribution systems
- Common Criteria certification
- Formal security analysis
- Alice-Bob protocol model
- Validation with AVISPA Tool
- **Conclusion on AADS**
- Research project AVANTSSAR

Conclusion (1) on AADS

- Challenges for AADS development
 - **pioneering** system design and architecture
 - **complex**, heterogeneous, distributed system
 - security is **critical** for both safety and business
- Common Criteria offer **adequate methodology** for assessment, at least for small components/systems
- **Systematic approach**, in particular **formal analysis**, enhances
 - **understanding** of the security issues
 - **quality** of specifications and documentation
 - **confidence** (of Boeing, customers, FAA, etc.) in the security solutions

Conclusion (2) on AADS

- Experience with SDS evaluation
 - Common Criteria **most widely accepted methodology**
 - Problem of **compositional** security evaluation not solved
 - Use formal analysis where **cost/benefit ratio** is best
 - Highly **precise design and documentation**:
assumptions, requirements
 - Shape system **architecture** to **support** security evaluation

- Future steps
 - **Key management** aspects:
Public Key Infrastructure (PKI) components etc.
 - **Configuration management**
with installation instructions and status/completion reports

Overview

- IT Security at Siemens Corporate Technology
- Software distribution systems
- Common Criteria certification
- Formal security analysis
- Alice-Bob protocol model
- Validation with AVISPA Tool
- Conclusion on AADS
- **Research project AVANTSSAR**

AVANTSSAR – an overview with examples

avantssar.eu

Automated Validation of Trust and Security of Service-oriented ARchitectures

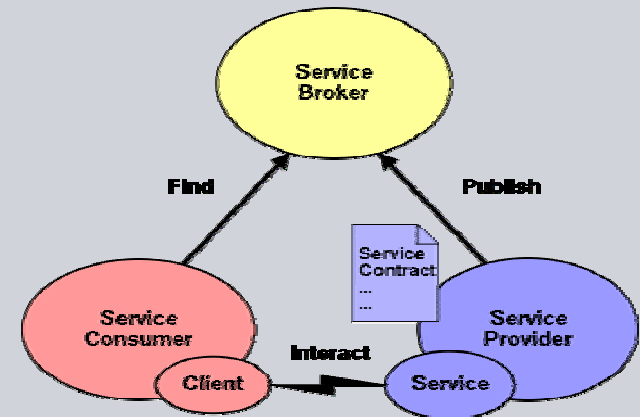

EU FP7-2007-ICT-1, ICT-1.1.4, Strep project no. 216471

Jan 2008 - Dec 2010, 590 PMs, 6M€ budget, 3.8M€ EC contribution

AVANTSSAR project motivation

ICT paradigm shift: from components to **services**, composed and reconfigured dynamically in a demand-driven way.

Trustworthy service may **interact** with others causing novel trust and security problems.

For the composition of individual services into service-oriented architectures, **validation** is dramatically needed.

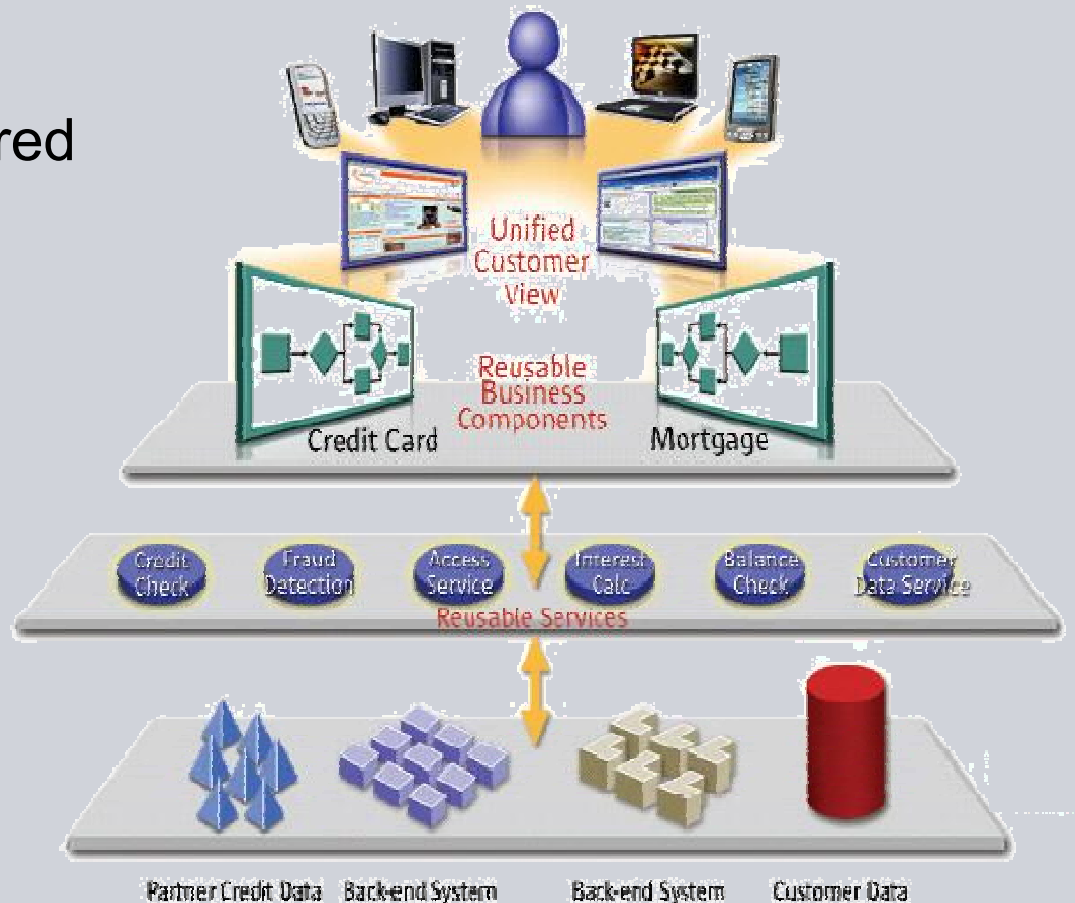

Example 1: Google SAML-based Single Sign-On (SSO)

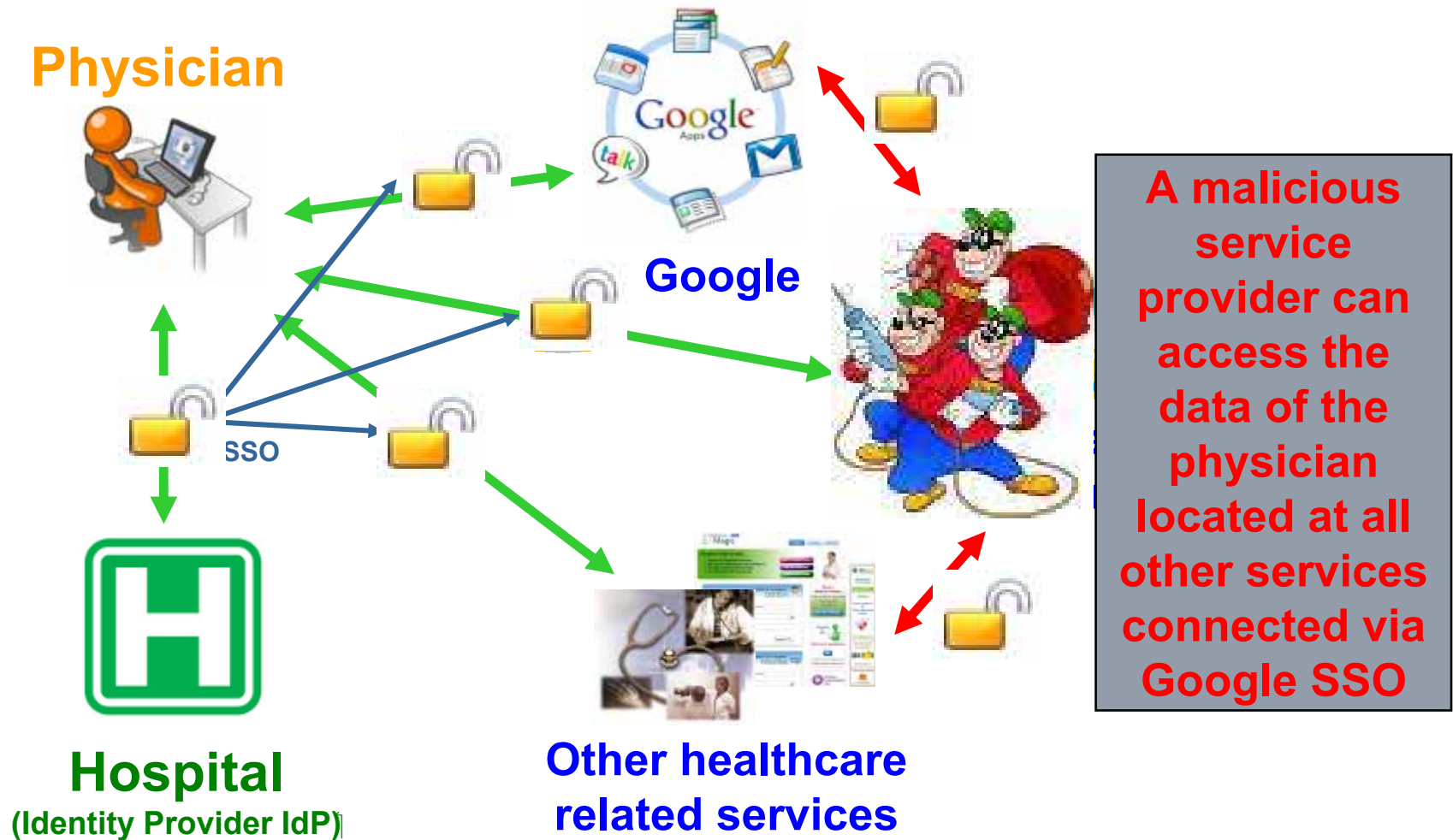

Example 1: Google SAML SSO protocol flaw

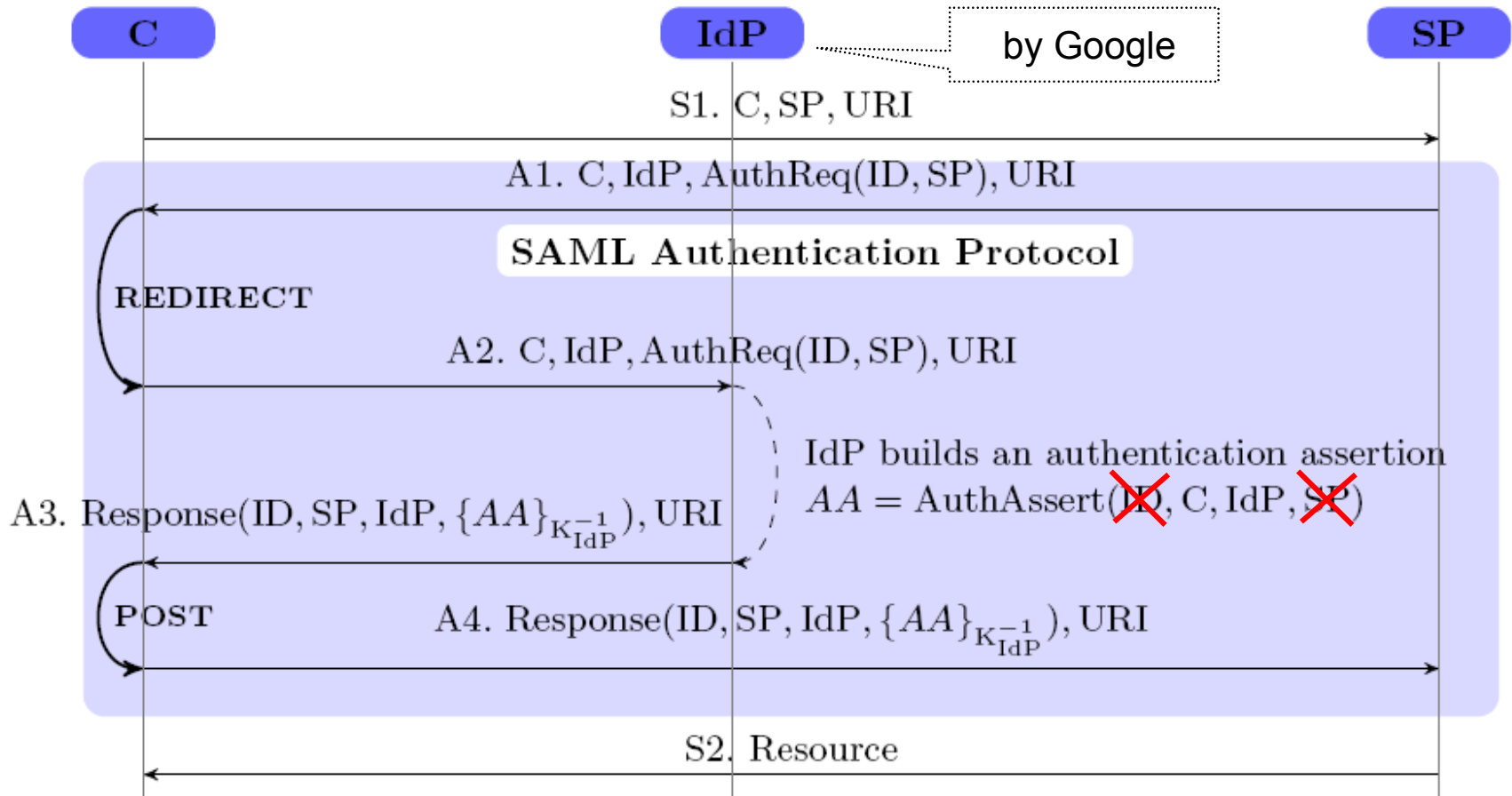

Fig. 1. SP-Initiated SSO with Redirect/POST Bindings

AVANTSSAR consortium

Industry

SAP Research France, Sophia Antipolis
Siemens Corporate Technology, München
 IBM Zürich Research Labs (part time)
 OpenTrust, Paris

Academia

Università di Verona
 Università di Genova
 ETH Zürich
 INRIA Lorraine
 UPS-IRIT Toulouse
 IEAT Timisoara

Expertise

Service-oriented enterprise architectures
 Security solutions
 Standardization and industry migration

Security engineering
 Formal methods
 Automated security validation

AVANTSSAR main objectives and principles

AVANTSSAR product: Platform for formal specification and automated validation of trust and security of SOAs

- **Formal language** for specifying trust and security properties of services, their policies, and their composition into service-oriented architectures
- **Automated toolset** supporting the above
- **Library** of validated industry-relevant case studies

Migration of platform to industry and standardization organizations

- **Speed up development** of new service infrastructures
- **Enhance** their **security** and robustness
- **Increase public acceptance** of SOA-based systems

AVANTSSAR project results and innovation

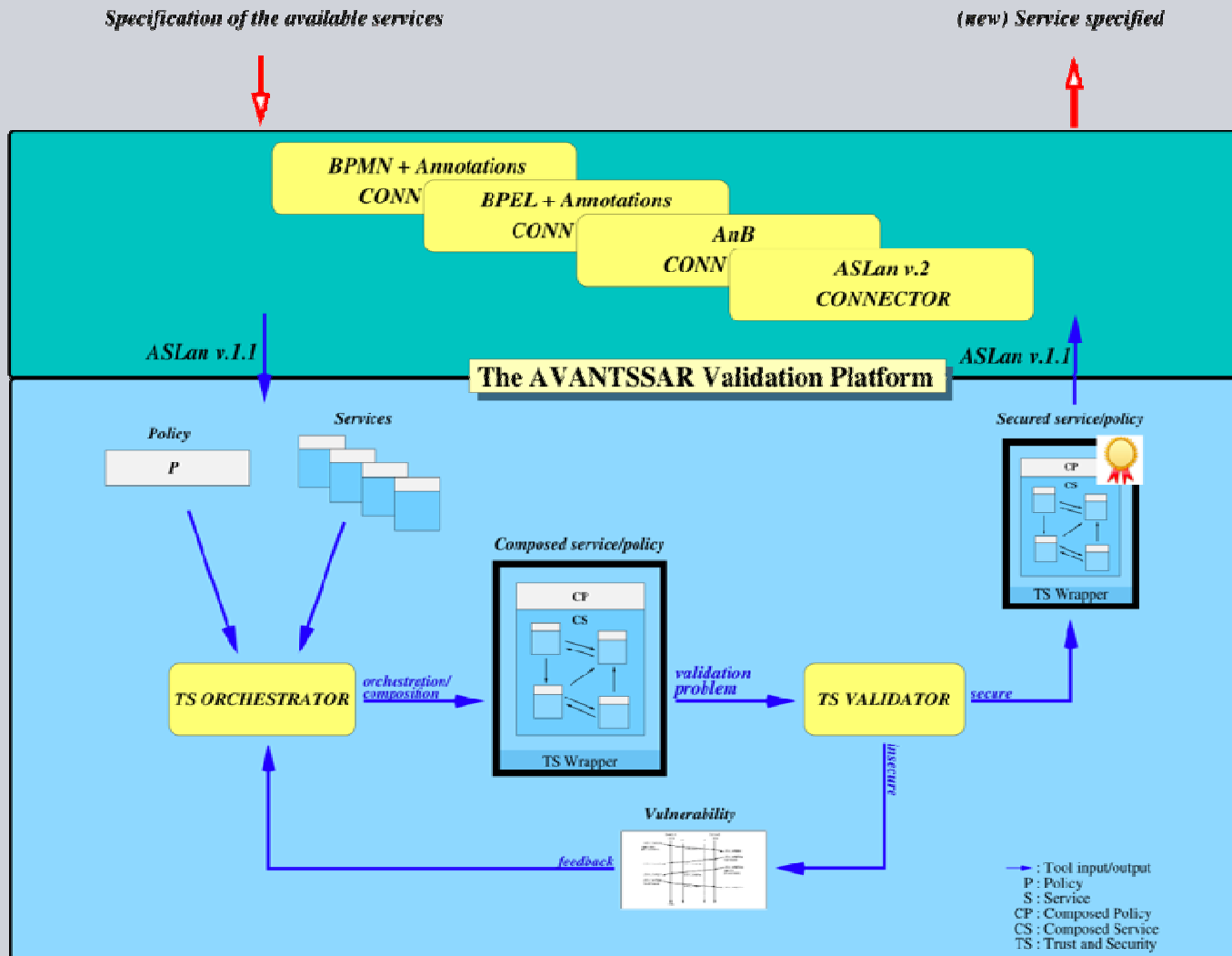

Example 2: Electronic Car Registration policies

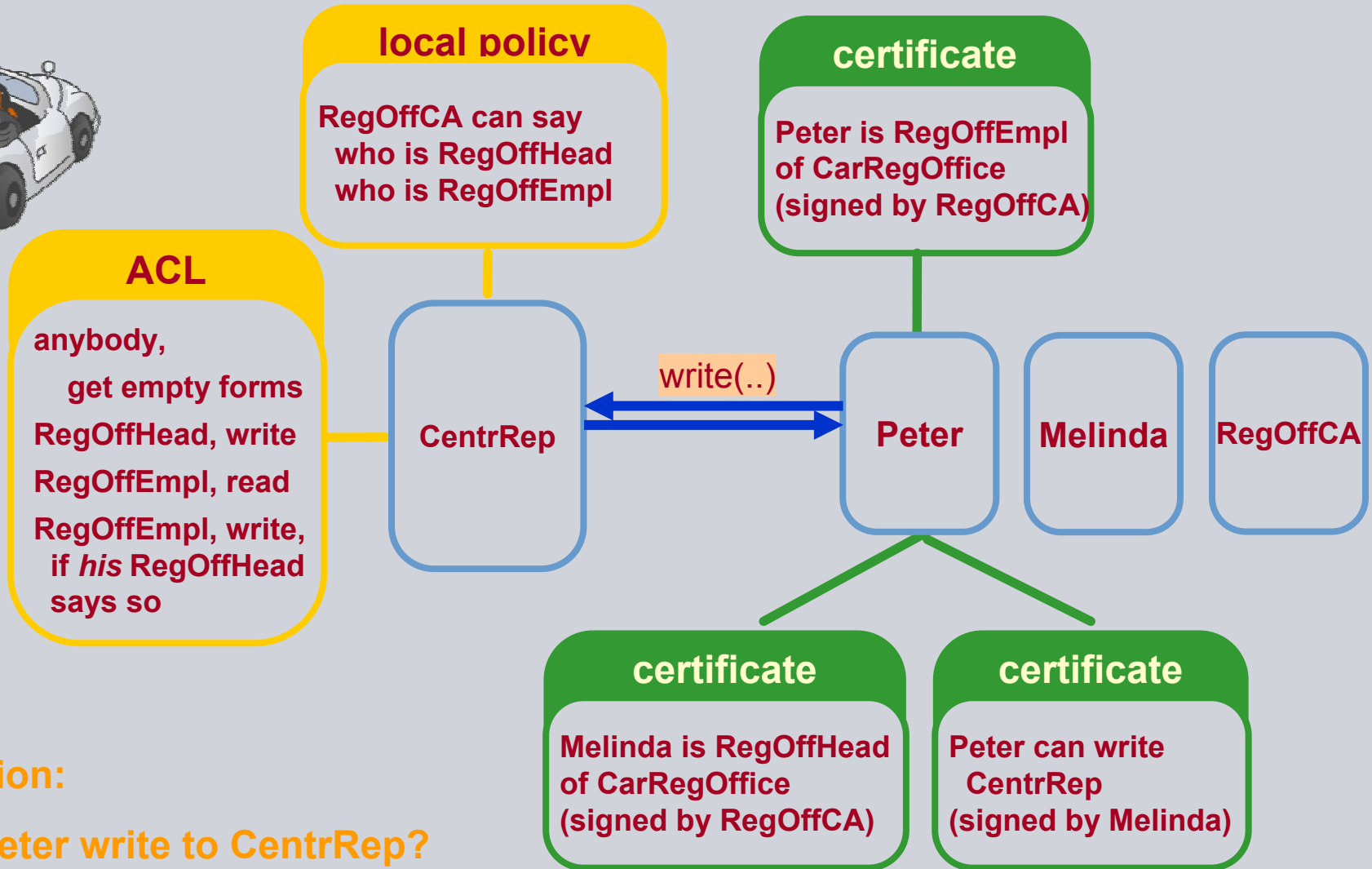

Question:

May Peter write to CentrRep?

Example 3: Process Task Delegation (PTD)

Authorization and trust management via token passing

There are three roles in the protocol (**C**, **A**, **TS**)

and potentially several instances for each role

The *client C* (or *user*) uses the system for

SSO, authorization and trust management

Each *application A* is in one domain,

each domain has exactly one active *token server TS*

A1 uses the system to pass to **A2** some **Order**

and an **ADT (Authorization Decision Token)**

- **Order** contains:
 - workflow task information
 - application data
 - information about the client **C** and his current activity to be delivered securely (integrity and confidentiality)
- **ADT** is mainly authorization *attributes* and *decisions*
 - sent via **TS1** and **TS2**, who may weaken it
 - must remain unaltered, apart from weakening by **TS**
 - must remain confidential among intended parties

C, **A1**, and **A2** must be authenticated among each other

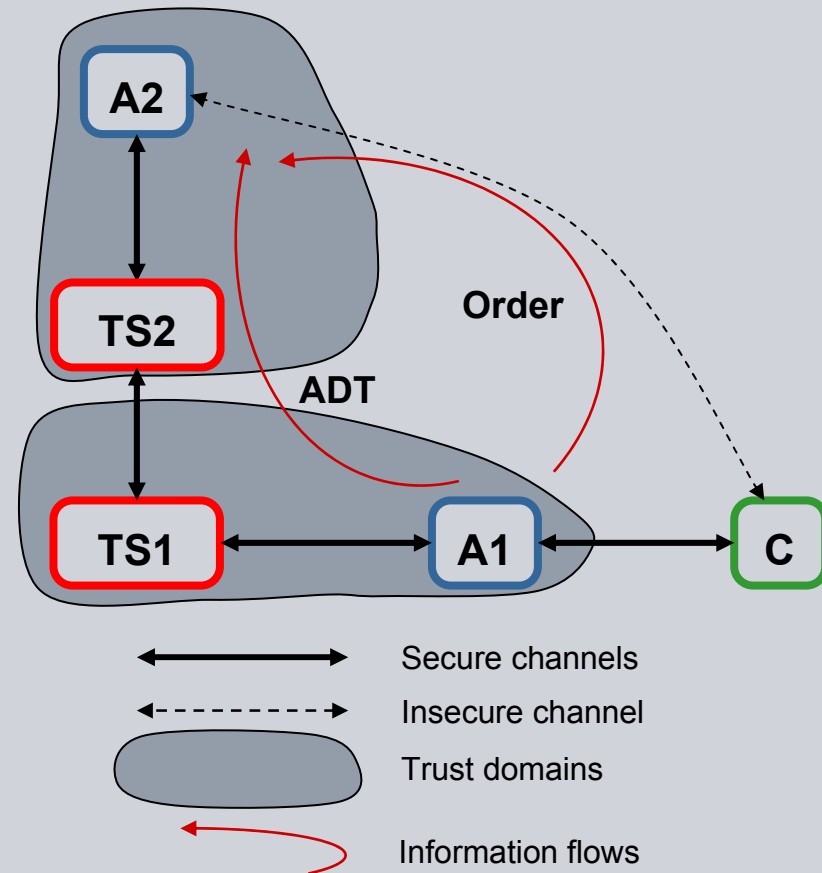

Security prerequisites:

PKI is used for **A** and **TS**, username & pwd for **C**

TS enforces a strict time-out

Example 3: ASLan++ model of A2

```

entity A2 (Actor: agent, TS2: agent) { % Applicaton2, connected with TokenServer2
  symbols
    C0,C,A1: agent;
    CryptedOrder, Order, Order0, Details, Results, TaskHandle, ADT, HMAC: message;
    SKey: symmetric_key;
  body { while (true) {
    select {
      % A2 receives (via some C0) a package from some A1. This package includes encrypted and
      % hashed information. A2 needs the corresponding key and the Authorization Decision Token.
      on (?C0 -> Actor: (?A1.Actor.?TaskHandle.?CryptedOrder)?.?HMAC): {
        % A2 contacts its own ticket server (TS2) and requests the secret key SKey and the ADT.
        Actor *->* TS2: TaskHandle;
      }
      % A2 receives from A1 the SKey and checks if the decrypted data corresponds to the hashed data
      on (TS2 *->* Actor: (?ADT.?SKey).TaskHandle & CryptedOrder = scrypt(SKey,?,?Details.?C)
        & HMAC = hmac(SKey, A1.Actor.TaskHandle.CryptedOrder)): {
        % A2 does the task requested by A1, then sends to A1 via C the results encrypted with the secret key.
        Results := fresh(); % in general, the result depends on Details etc.
        Actor -> C: Actor.C.A1. scrypt(SKey,Results);
      }
    }
  }
  goals
    authentic_C_A2_Details: C *-> Actor: Details;
    secret_Order: secret (Order, {Actor, A1});
}

```

AVANTSSAR current status



SIEMENS

WP2: ASLan++ supports the formal specification of trust and security related aspects of SOAs, and of static service and policy composition

WP3: Techniques for: satisfiability check of policies, model checking of SOAs w.r.t. policies, different attacker models, compositional reasoning, abstraction

WP4: Deploy first prototype of **AVANTSSAR Platform**

WP5: Formalization of **industry-relevant problem cases** as ASLan++ specifications and their validation

WP6: Ongoing dissemination and migration into scientific community and industry

AVANTSSAR impact: industry migration

Services need to be securely combined according to evolving trust and security requirements and policies.

A rigorous demonstration that a composed SOA meets the security requirements and enforces the application policy will:

- significantly increase customers' confidence
- enable customers to fully exploit the benefits of service orientation

Integration of AVANTSSAR Platform in industrial development environment

The AVANTSSAR Platform will advance the security of industrial vendors' service offerings: **validated, provable, traceable.**

AVANTSSAR will thus strengthen the competitive advantage of the products of the industrial partners.

